

MATERIAL

Nickel-plated die-cast zinc.

STANDARD EXECUTIONS

- **GN 614.1-B:** two-side fixing wings.
- **GN 614.1-L:** left-side fixing wing with positioning pin.
- **GN 614.1-R:** right-side fixing wing with positioning pin.

FEATURES AND APPLICATIONS

GN 614.1 holders for spring plungers optimise the use of smooth ball spring plungers GN 614 (see page 964) and GN 614-NI (see page 964).

Application example

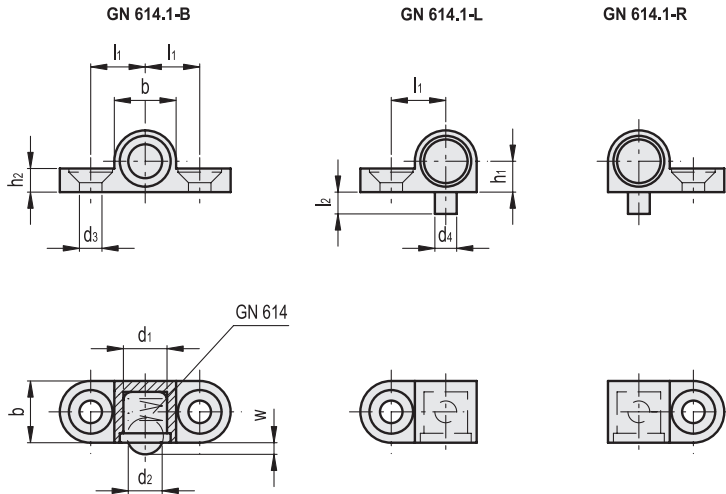
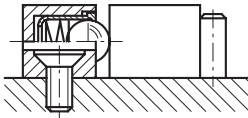

Conversion Table	
1 mm = 0.039 inch	
d1	
mm	inch
6	0.24
8	0.31

METRIC

Code	Description	d1	d2	d3	d4-0.05	l1-0.1	l2	b	h1±0.05	h2	w-0.1	Screw	⚖
GN.32205	GN 614.1-6-B	6	5	3.2	3	7.5	3	8.5	4.25	3.2	1.5	M3	5
GN.32206	GN 614.1-8-B	8	6.5	4.3	4	9.5	4	10.5	5.25	4.2	1.8	M4	5
GN.32215	GN 614.1-6-L	6	5	3.2	3	7.5	3	8.5	4.25	3.2	1.5	M3	5
GN.32216	GN 614.1-8-L	8	6.5	4.3	4	9.5	4	10.5	5.25	4.2	1.8	M4	5
GN.32225	GN 614.1-6-R	6	5	3.2	3	7.5	3	8.5	4.25	3.2	1.5	M3	5
GN.32226	GN 614.1-8-R	8	6.5	4.3	4	9.5	4	10.5	5.25	4.2	1.8	M4	5

- 1
- 2
- 3
- 4
- 5
- 6
- 7
- 8
- 9
- 10
- 11
- 12
- 13
- 14
- 15
- 16
- 17
- 18

Indexing and positioning elements